

Flambe 
by Concassé



CATALOG

FOUR AND SIX BURNER GRILL

STAINLESS STEEL GRILL

ID DESCRIPTION

EESF4X24 STAINLESS STEEL GRILL 4 BURNERS 24" 120,000 BTUS

EESF6X36 STAINLESS STEEL GRILL 6 BURNERS 36" 180,000 BTUS



- Construction
 - Stainless steel
 - Interior and exterior

Measures:
Grill 4 burners
24" x 31" x 14.5"
Grill 6 burners
36" x 31" x 14.5"

- Grill
 - Cast Iron
 - Reinforced
 - Removable

Net weight: 121.25 Lb
Gross weight: 165.34Lb

- Burners
 - High capacity open
 - 30,000 BTU/hr.

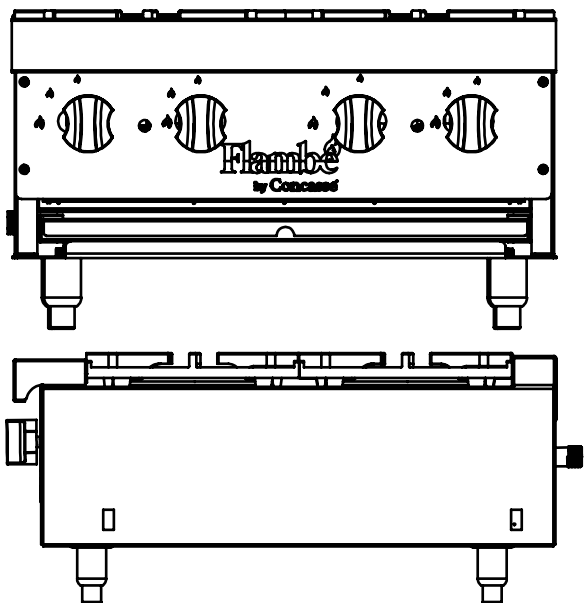
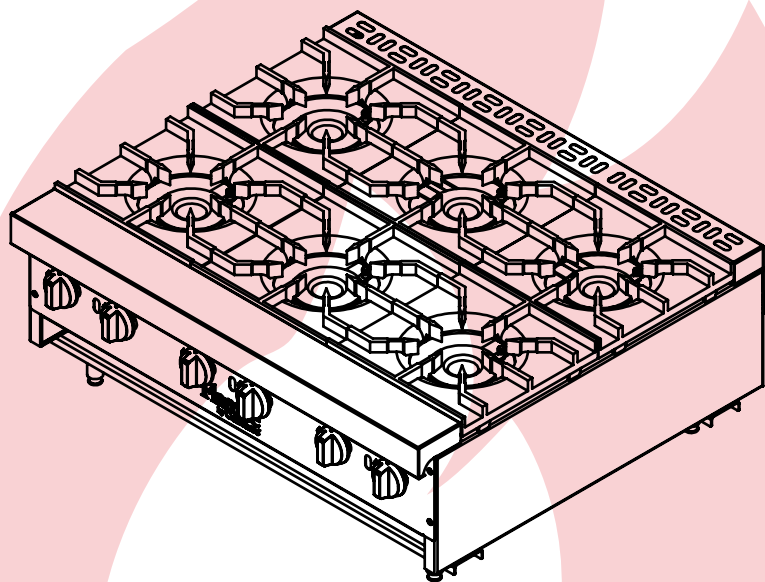
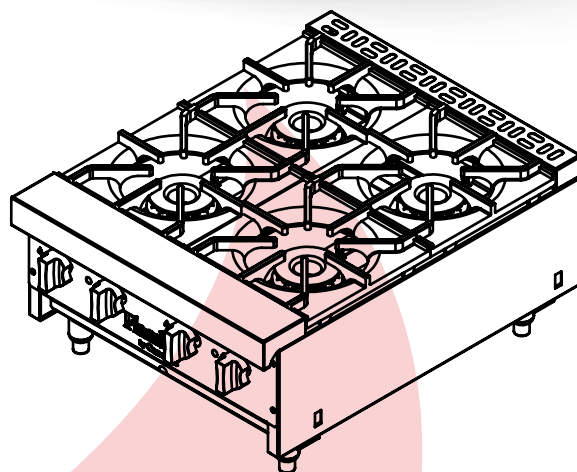

TWO, THREE AND FOUR BURNER GRIDDLE

STAINLESS STEEL GRIDDLE

ID DESCRIPTION

EPAF2X24 STAINLESS STEEL GRIDDLE 2 BURNERS 24" 46,000 BTUS

EPAF3X36 STAINLESS STEEL GRIDDLE 3 BURNERS 36" 59,000 BTUS

EPAF4X48 STAINLESS STEEL GRIDDLE 4 BURNERS 48" 92,000 BTUS



- Construction
 - Stainless steel
 - Inside and outside
- Design
 - Aesthetic
 - Modular
- Burners
 - High Capacity U Type
 - 23,000 BTU/hr.
 - Removable
- Independent pilots
- Water and fat collection tray
- Factory Gas/LP
- Adjustable leveling feet

Measures:

Griddle 2 burners

24" x 31" x 14.5"

Griddle 3 burners

36" x 31" x 14.5"

Griddle 4 burners

48" x 31" x 14.5"

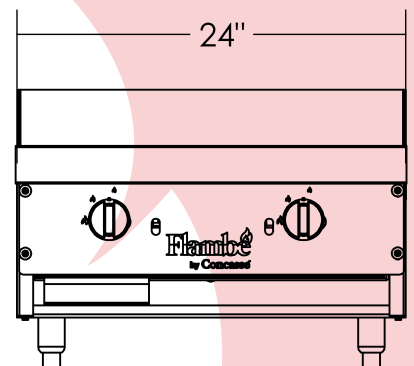
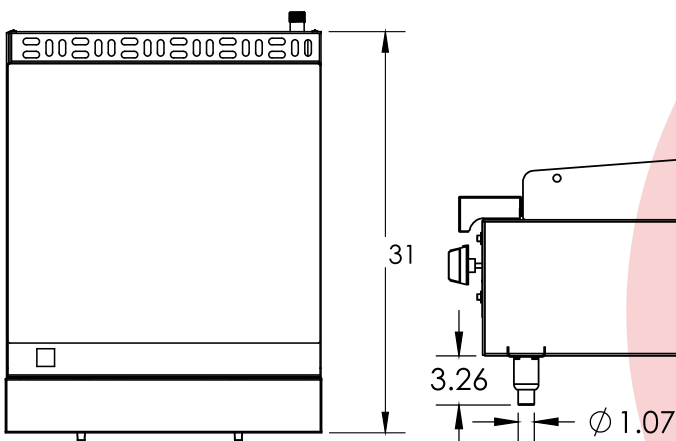
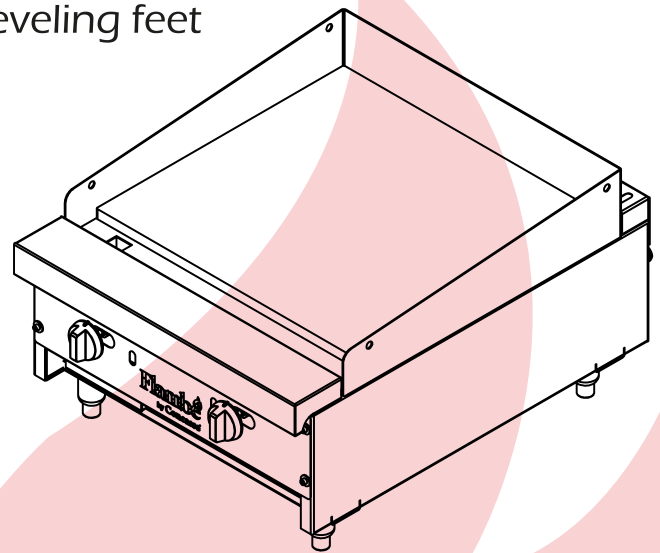

20 LITERS FRYER

STAINLESS STEEL FRYER

ID DESCRIPTION

EFREF2X20 STAINLESS STEEL FRYER, 3 BURNERS, 35,000 BTU PER BURNER, 20LTS, 2 CHAINS

- Factory configured with LP gas.
- 105,000 Total BTU's
- 20 liter tub capacity
- Stainless Steel Construction
- 3 removable cast iron burners.
- Oil drain tube with extension.
- Safety thermostat at 450 °F

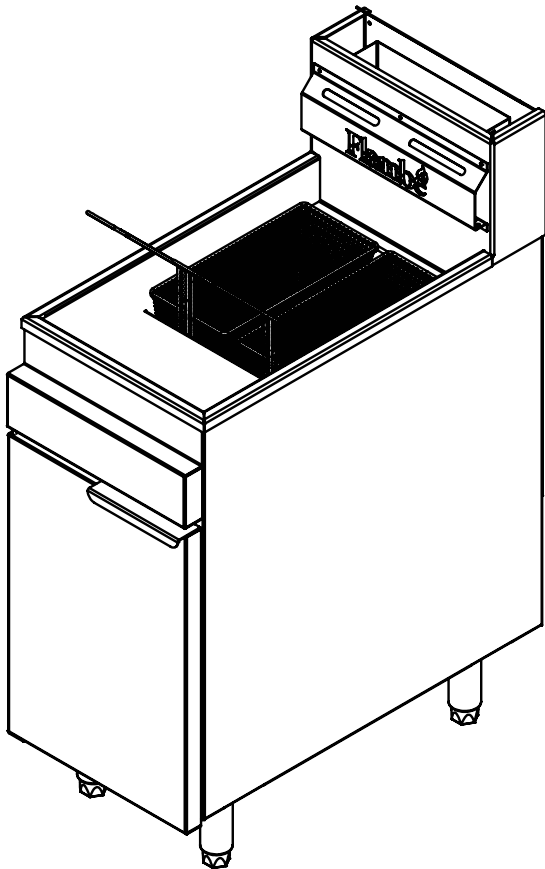

2 BURNER STOVE

STAINLESS STEEL STOVE

ID	DESCRIPTION
EESTF2X18	STAINLESS STEEL STOVE 2 BURNERS 18" 45,000 BTU PER BURNER

- Factory configured with LP gas
- 90,000 total BTU's
- Stainless Steel Construction
- High capacity concentric burners made of cast iron, removable.
- Removable grill made of Cast Iron.
- Independent pilots for each burner
- Tray for grease and waste.
- Adjustable height leveling feet up to 8"F

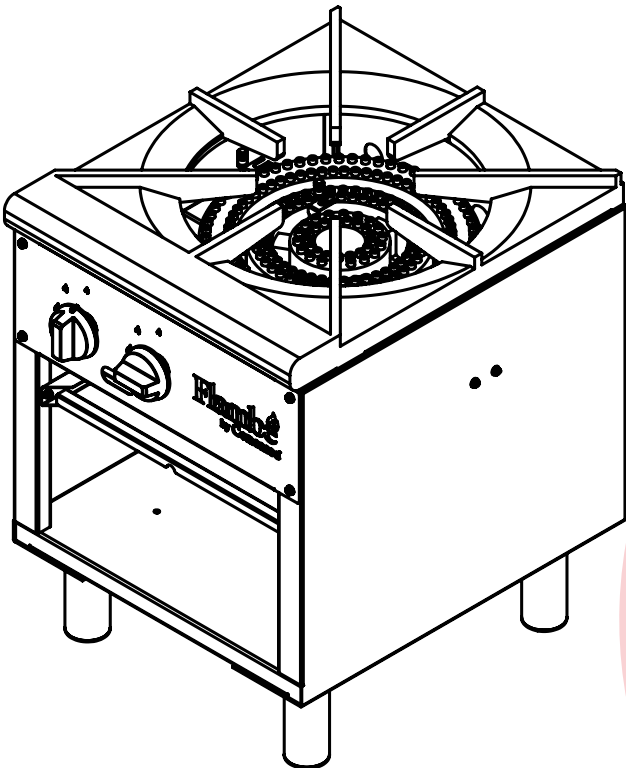

STOVE

- 6 Solid octagonal burners in cast iron, each with 24,000 BTU/h.
- 3 Upper grates in cast iron mounted on the structure.
- 6 Individual pilots.
- 1 Thermostat with integrated safety valve, range from 212 to 572°F.
- 1 Tubular burner of 26,000 BTU/h.
- 1 Solid door with perimeter seal for airtight closure.
- 4 adjustable legs.
- Total external dimensions, without packaging: width: 34 ⁴¹/₆₄" (88cm), depth: 31 ⁵⁷/₆₄" (81cm), height: 41 ⁴⁷/₆₄" to 42 ²⁹/₃₂" (106 - 109cm).





Flambé

144